



TSR_{IF}

ASSEMBLY MANUAL

TSRf Component Description	2
Important Foreword	3
List of assemble parts	4
Parts in exploded view	6
TSRf mechanical cable guide	8
TSRf Shimano Di2 cable guide	9
TSRf Fitting guide	10
Aerobar position adjustment	11
Extension bar & riser kit adjustment	13
Saddle position adjustment	15
Front brake adjustment	16
Screw torque value guide	16
Complete Bike Assembly	
Unboxing & assembly	17
Take out the bike	18
Assemble the riser kit	19
Assemble the Armpads and extended plates	21
Assemble the seat post	22
Front wheel installation and double-check	23
Recommended torque value	25
Carbon Fiber Bike Statement	26
Warranty Terms & Conditions	27

TSRf Component Description

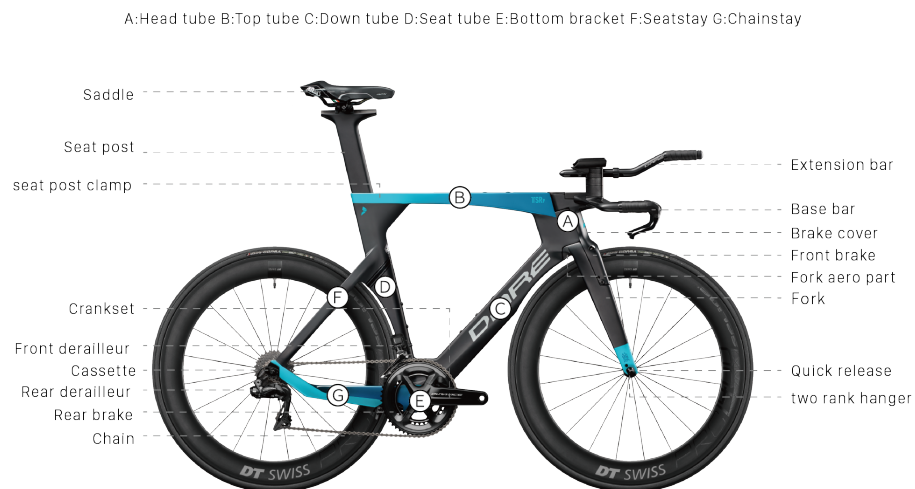

i Notice Symbol

This symbol highlights the important operating steps.

A Caution Symbol

This symbol indicates operating steps that must be obeyed to prevent injuries or accidents.

- This manual does not cover every aspect of your bicycle nor aims to teach you how to ride proficiently.
- This manual is to provide information about your bicycle and to provide caution where necessary.
- This manual does not contain a guide to assemble a complete bike.
- Regarding non-DARE component information, please refer to such information provided by those manufacturers.
- Since bike technology is updated from time to time, please follow updates on our website: www.dare-bikes.com.

Important Foreword

THANK YOU FOR CHOOSING DARE BIKES!

1. Carbon bikes have a limited lifespan.

The majority of people assume that bikes can be used forever, especially the more expensive ones. However, just like other vehicles, a bicycle is composed of many components with a limited useful lifespan. Bicycles therefore need frequent maintenance and adjustment to ensure that each component performs at its optimal capacity during its lifespan.

2. The importance of maintenance, repair and safety

The way in which a bicycle is ridden and maintained will have a significant influence upon its lifespan. Therefore, it is essential that maintenance and repairs are performed regularly and to a high standard. This will allow the bicycle to perform at its best for the duration of its lifespan whilst being safer to ride.

Using the bike correctly, wearing suitable safety equipment and riding competently are the three elements to ensure your safety and to maximise the bicycle's lifespan.

Please follow the MAINTENANCE PRACTICE manual to perform the regular maintenance checks.

For your own safety please do NOT attempt to perform your own repairs unless you have the necessary skills. If you are unclear please contact the service centre or email to: service@dare-bikes.com.

3. Storage

Any damage to the paint coat or frame structure/component caused by UV light, rain, moisture, seawater, mud, sweat or heat will decrease the lifespan of the bicycle. The bicycle needs to be stored away from UV exposure, rain and moisture. If the bike is exposed to salt for example on highways, it will require immediate cleaning and drying to prevent corrosion.

On each occasion before being stored, it is important to undergo cleaning and lubrication. Please refer to DARE ROAD BIKE INSTRUCTION regarding the maintenance of each component.

4. Please carefully read the manual to understand the warranty terms and conditions.

This is very important as it will help you to understand more about your bike and your rights. Furthermore, this manual can be presented to the authorized reseller during routine maintenance and repair so a record can be kept. For further details regarding specification, maintenance, and warranty terms, please visit our website: <https://www.dare-bikes.com>

List of Assemble Parts

A Stem

A1	Stem	1
A2	Stem blot M5*12mm	2
A3	Alloy stem cap	1
A4	M5 bolt washer	6
A5	Stem blot M5*15mm	4
A6	Fork stem cap	1
A7	Fork stem cap screw M6*30mm	1
A8	Screw waterproof cap	2

B Stem adjustment kits

B1	Stem rubber end-cover	1
B2	Basebar fixed plug	1
B3	Stem bottle cage riser	1
B4	Stem bottle cage riser screw M5*10mm	2
B5	Stem riser 10mm	1
B6	Stem riser 15mm	1
B7	Stem riser bolt M5*25mm	4
B8	Stem riser bolt M5*30mm	4
B9	Stem riser bolt M5*40mm	4

C Computer mount

C1	Mount bridge	1
C2	GARMIN mount	1
C3	GoPro mount	1

D Extension bar kits

D1	Arm pad(L)	1
D2	Arm pad(R)	1
D3	Arm pad plate(L)	1
D4	Arm pad plate(R)	1
D5	Extended plate(L)	1
D6	Extended plate(R)	1
D7	Arm pad mount(L)	1
D8	Arm pad mount(R)	1
D9	Extension bar clamp(L)	1
D10	Extension bar clamp(R)	1

E Extension bar screws

E1	Screw M6*9mm	4
E2	Screw M6*11mm	4
E3	Screw M6*30mm	4
E4	Screw M6*45mm	4
E5	Screw M6*60mm	4
E6	Screw M6*75mm	4

F Extension bar mandrel bolts

F1	Bolt M6*80mm	4
F2	Bolt M6*50mm	4

G Extension bar adjustment kits

G1	Washer (1.5mm)	4
G2	Washer (3mm)	28
G3	Basebar oval plate	2
G4	Riser (5mm)	6
G5	Riser (20mm)	4
G6	Riser (30mm)	2

H Brake kits

H1	Front brake (Fouriers direct mount)	1
H2	End cap 5mm	1
H3	Rear brake (Shimano direct mount) (Optional purchase)	1

I Frame assembly parts

I1	Front derailleur spheric washer	1
I2	End cap 4mm	1

J Seat post kits

J1	Seat post clamp	1
J2	Rubber plug	1

K Rear hanger

K1	Standard hanger	1
K2	Direct mount hanger (additional)	1

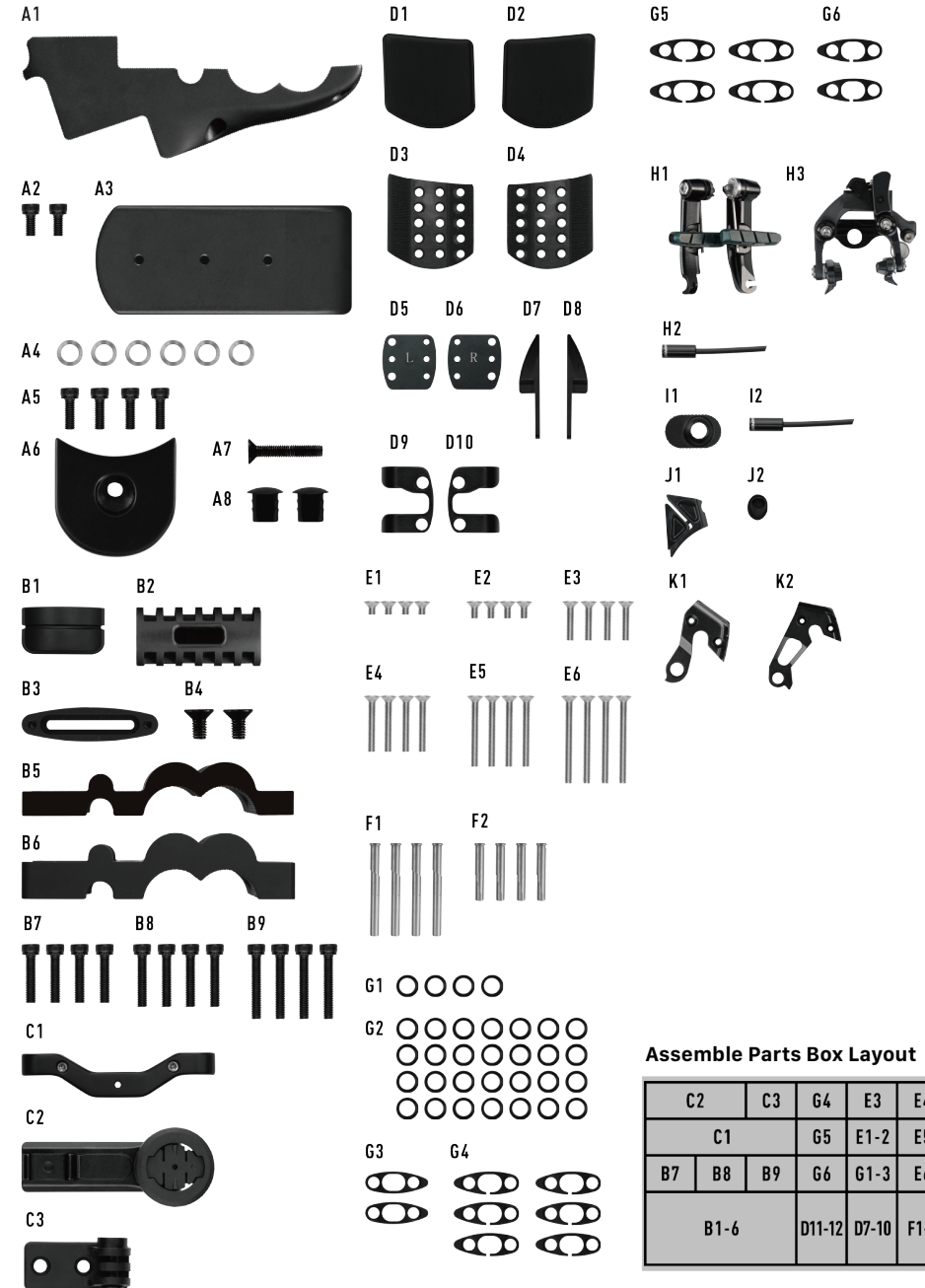

Assemble Parts Box Layout

C2	C3	G4	E3	E4	
C1		G5	E1-2	E5	
B7	B8	B9	G6	G1-3	E6
B1-6		D11-12	D7-10	F1-2	

Parts In Exploded View

! Carbon fiber parts will be damaged because of massive tightening force. If the damage is caused, the product will NOT be covered by warranty and possible injury risk might occur to the rider. Please use the correct torque wrench and follow the maximum torque value. And depending on the situation, use commercial oil to increase parts' adhesion.

i To minimize air resistance, TSRf contains internal routing system inside the frame. This means you must be extra careful when assembling. We suggest to have the fitting done and test assembly first before the final assembly.

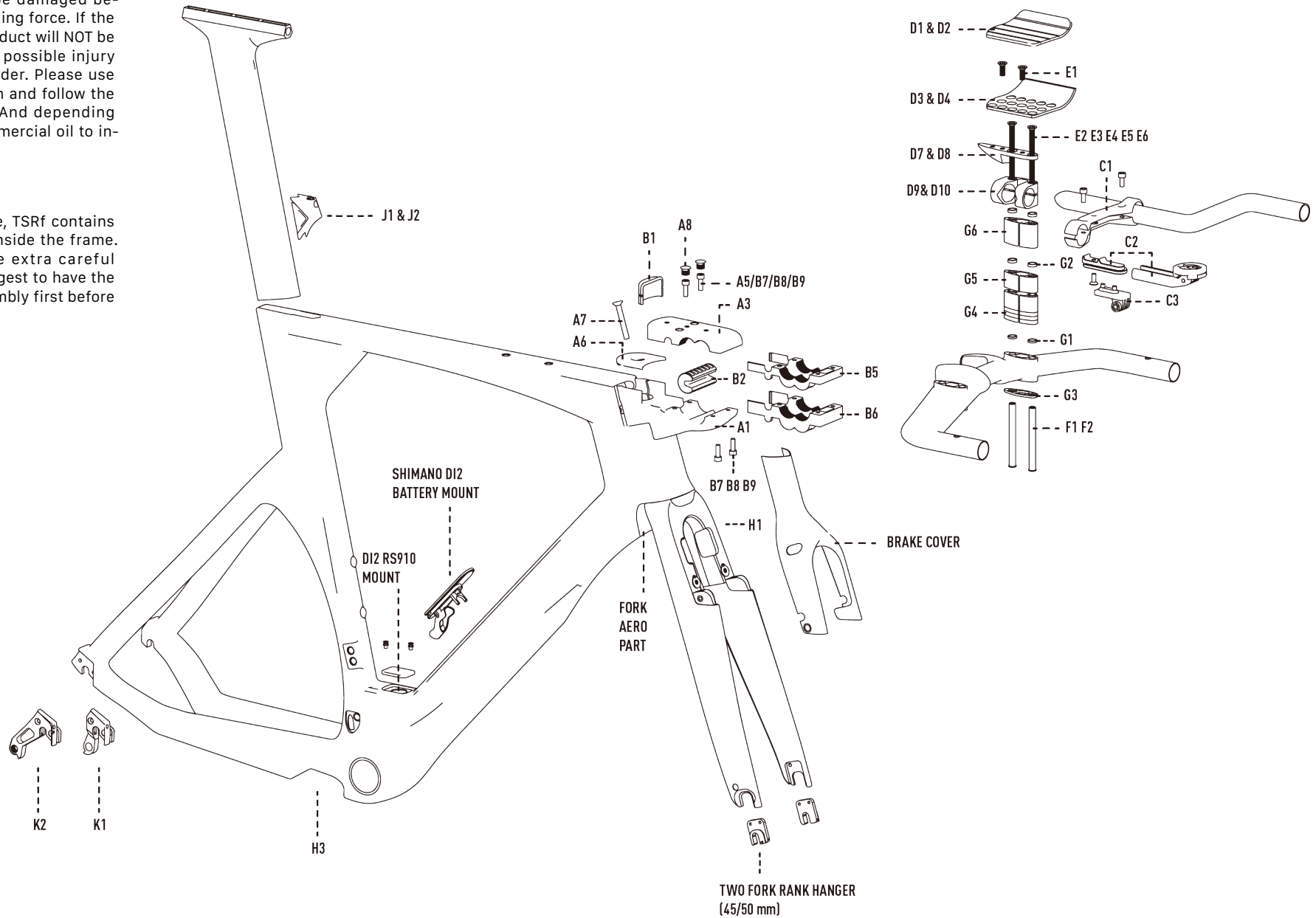

TSRf Mechanical Cable Guide

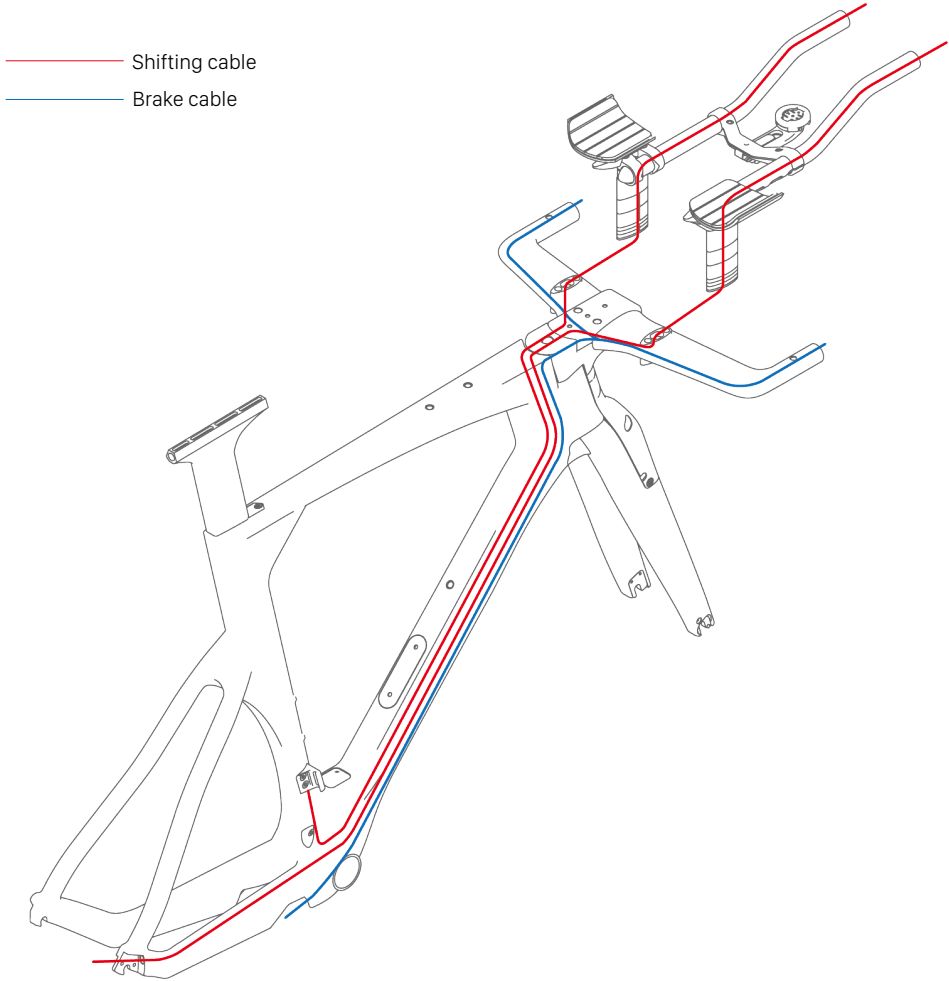

— Shifting cable
— Brake cable

i Compare to electronic shifting wire the mechanical wire shell is relatively harder. So please be sure to pay more patience and care when assembling.

i The extension bars provide five elliptical holes, each of which provides fine adjustment of 1 cm in between. When assembling, please select the best hole according to your personal needs.

TSRf Shimano Di2 Cable Guide

i The extension bar provides five holes, each of which provides fine adjustment of 1cm in between. When assembling, please select the best hole according to your personal needs.

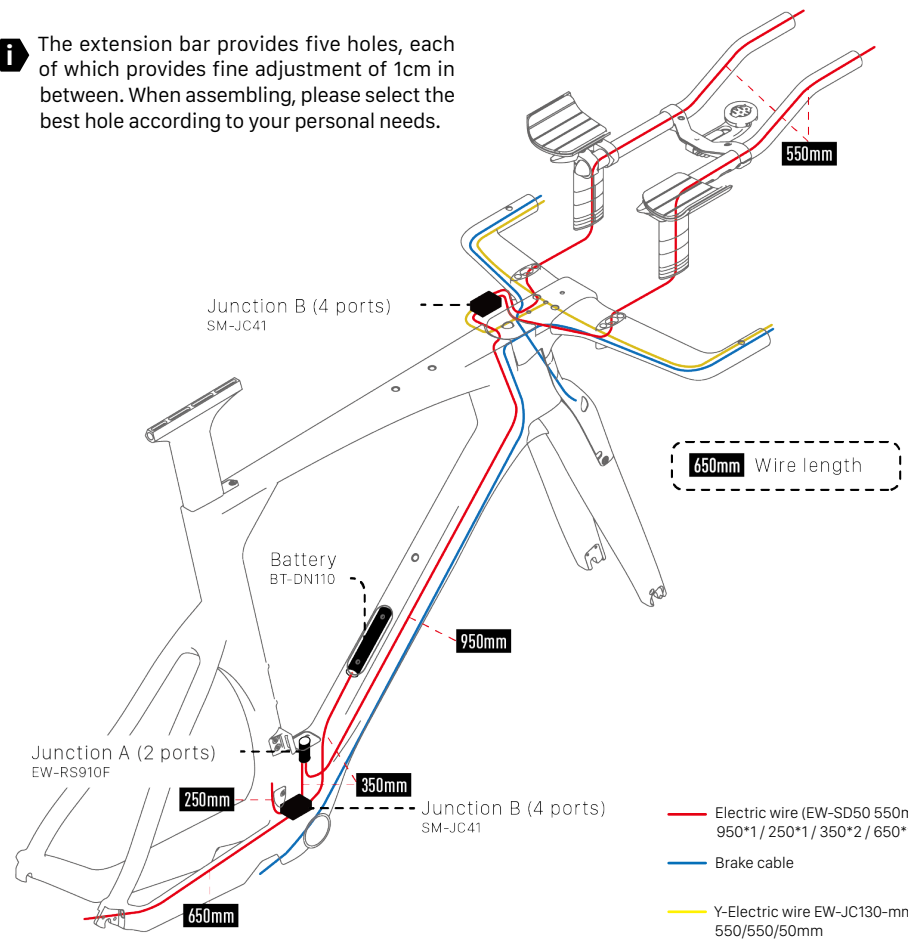

650mm Wire length

— Electric wire (EW-SD50 550mm*2 / 950*1 / 250*1 / 350*2 / 650*1)
— Brake cable
— Y-Electric wire EW-JC130-mm 550/550/50mm

DI2 WIRE MAP

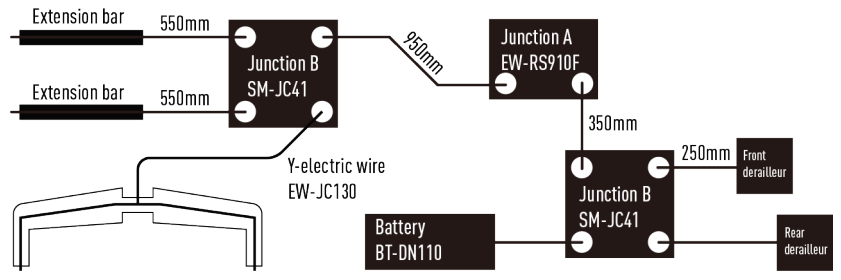

TSRf Fitting Guide

Frame size / Basebar

- Step 1: Confirm your standover and BR/BS value
- Step 2: Confirm stem riser and aerobar position

Extension bar height / Arm pad / Saddle

- Step 3: Find out frame's MR and MS value
- Step 4: Find out the needed amount of risers
- Step 5: Find out the arm pad position
- Step 6: Find out the saddle position

ⓘ Please have your personal fitting data for TT bikes ready before proceed the above steps.

Measurement Abbreviation Indication

R	Reach	S	Stack
BR	Basebar Reach	BS	Basebar Stack
MR	Riser Kit Mount Reach	MS	Riser Kit Mount Stack
AR	Armpad Reach	AS	Armpad Stack

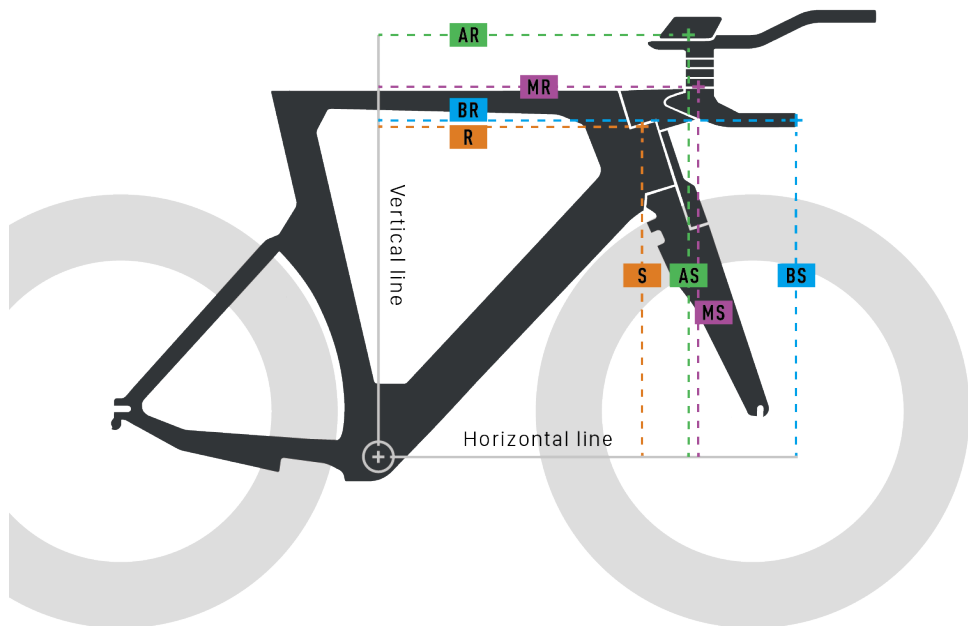

Step 1: Confirm your standover and BR/BS value

Base on your fitting data, use your inside leg length to find out standover. (Remember, your inside leg length should be 30mm longer than the bike's standover.) Then find out the closest BR and BS values in chart A. Their intersecting cell shall indicate the advised TSRf frame size and basebar position value.

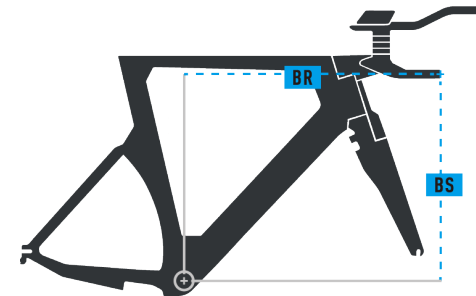

CHART A

BR / BS		BR (BASEBAR REACH)							
		598	618	610	630	623	643	638	658
BS (BASEBAR STACK)	605							A 638/605	I 658/606
	595							B 638/596	J 658/596
	590					A 623/590	I 643/590	C 638/591	K 658/591
	580					B 623/580	J 643/580	D 638/581	L 658/581
	560-571			A 610/574	I 630/574	C 623/575	K 643/575	E 638/561	M 658/561
	550-565			B 610/564	J 630/564	D 623/565	L 643/565	F 638/551	N 658/551
	545-560	A 598/558	I 618/558	C 610/559	K 630/559	E 623/545	M 643/545	G 638/546	O 658/546
	535-550	B 598/548	J 618/548	D 610/549	L 630/549	F 623/535	N 643/535	H 638/536	P 658/536
	530-545	C 598/543	K 618/543	E 610/529	M 630/529	G 623/530	O 643/530	L	
	520-535	D 598/533	L 618/533	F 610/519	N 630/519	H 623/520	P 643/520	408/528	
	515	E 598/513	M 618/513	G 610/514	O 630/514	M		840	
	505	F 598/503	N 618/503	H 610/504	P 630/504	393/512			
500	G 598/498	O 618/498	S		824				
490	H 598/488	P 618/488	380/496						
FRAME SIZE	XS		770						
R / S	368/480								
STANDOVER	743								

Step 2: Confirm stem riser and aerobar position

Use the content cells letter (A~P) found in **CHART A**, you are able to find the same letter in **CHART B**. Then you are given the amount of stem riser needed and the position (rear or front) to install basebar.

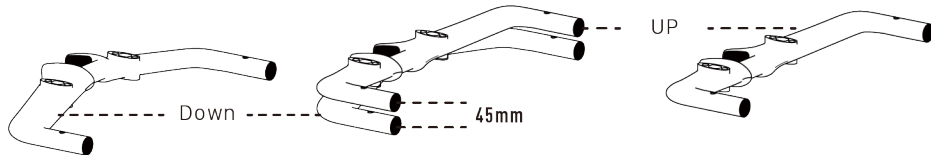
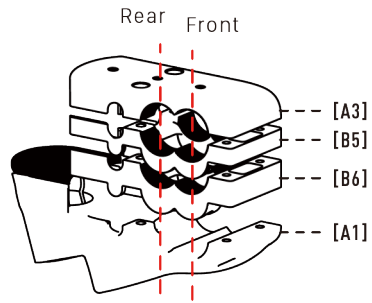

CHART B	Basebar: Rear	Basebar: Front
Stem Riser: [B5] [B6] Bolts: [B9] Basebar: UP	A	I
Stem Riser: [B6] Bolts: [B8] Basebar: UP	B	J
Stem Riser: [B5] Bolts: [B7] Basebar: UP	C	K
Stem Riser: None Bolts: [A5] Basebar: UP	D	L
Stem Riser: [B5][B6] Bolts: [B9] Basebar: Down	E	M
Stem Riser: [B6] Bolts: [B8] Basebar: Down	F	N
Stem Riser: [B5] Bolts: [B7] Basebar: Down	G	O
Stem Riser: None Bolts: [A5] Basebar: Down	H	P

Step 3: Find out frame's MR and MS value

Again, use the same content cells letter (A~P) found in **CHART A** to locate the exact spot in **CHART C** to find MR and MS value.

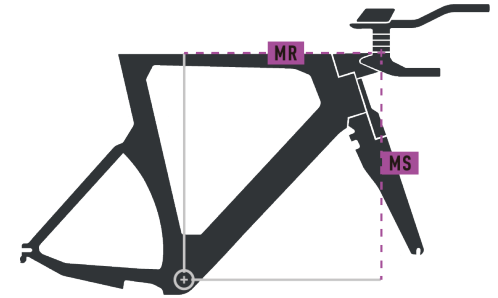

CHART C

MR / MS	MR (RISER KIT MOUNT REACH)											
MR (RISER KIT MOUNT STACK)									A 481/605	I 501/605		
									B 481/595	J 501/595		
							A 466/589	I 486/589	C 481/590	K 501/590		
							B 466/579	J 486/579	D 481/580	L 501/580		
							A 453/573	I 473/573	C 466/574	K 486/574	E 481/590	M 501/590
							B 453/563	J 473/563	D 466/564	L 486/564	F 481/580	N 501/580
	A 441/557	I 461/557	C 453/558	K 473/558	E 466/574	M 486/574	G 481/575	O 501/575				
	B 441/547	J 461/547	D 453/548	L 473/548	F 466/564	N 486/559	H 481/565	P 501/565				
	C 441/542	K 461/542	E 453/558	M 473/558	G 466/559	O 486/564	L					
	D 441/532	L 461/532	F 453/548	N 473/548	H 466/549	P 486/549	408/528					
	E 441/542	M 461/542	G 453/543	O 473/543	M		840					
	F 441/532	N 461/532	H 453/533	P 473/533	393/512							
	G 441/527	O 461/527	S		824							
	H 441/517	P 461/517	380/496									
FRAME SIZE	XS		770									
R / S	368/480											
STANDOVER	743											

Step 4: Find the needed amount of risers

To find out the needed amount of risers, please use your AS value, determined by your fitting data, then minus 40mm (extension bar clamping height) and MS value, found in step 3, the result

will be your riser height. Base on your riser height, you can find out the advised amount of risers and which bolt and screw you need in **CHART D**.

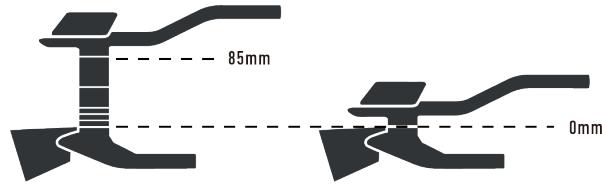

CHART D

Riser height	Qty of risers			Bolts	Screw	
	5mm[G4]	20mm[G5]	30mm[G6]			
85	3	2	1	80mm [F1]	75mm [E6]	
80	2	2	1		60mm [E5]	
75	1	2	1		45mm [E4]	
70	0	2	1		30mm [E3]	
65	3	1	1		50mm [F2]	45mm [E4]
60	2	1	1			30mm [E3]
55	1	1	1			45mm [E4]
50	0	1	1			30mm [E3]
45	1	2	0			45mm [E4]
40	0	2	0			30mm [E3]
35	3	1	0	45mm [E4]		
30	2	1	0	30mm [E3]		
25	1	1	0	50mm [F2]	45mm [E4]	
20	0	1	0		30mm [E3]	
15	3	0	0		45mm [E4]	
10	2	0	0		30mm [E3]	
5	1	0	0		45mm [E4]	
0	0	0	0	30mm [E3]		

! Please do not use a combination of short bolts [F2] and long screws [E5][E6].

Step 5: Find the arm pad position and arrangement

Forward position adjustment:

Base on your fitting data, find the AR value and minus MR, found in step 3. AR - MR = the advised forward adjustment length. Arm pads [D5] and [D6] provide 5 forward positions, 15mm spacing in between each position. Please see the diagram below for your reference.

Left and right adjustment:

The width between basebar riser mounts is 150mm. [D5] and [D6] provide 3 left and right positions, 20mm spacing in between each position.

If you need wider arrangement, simply replace [D7] and [D8] with [D9] and [D10], that gives you up to 30mm maximum adjustment.

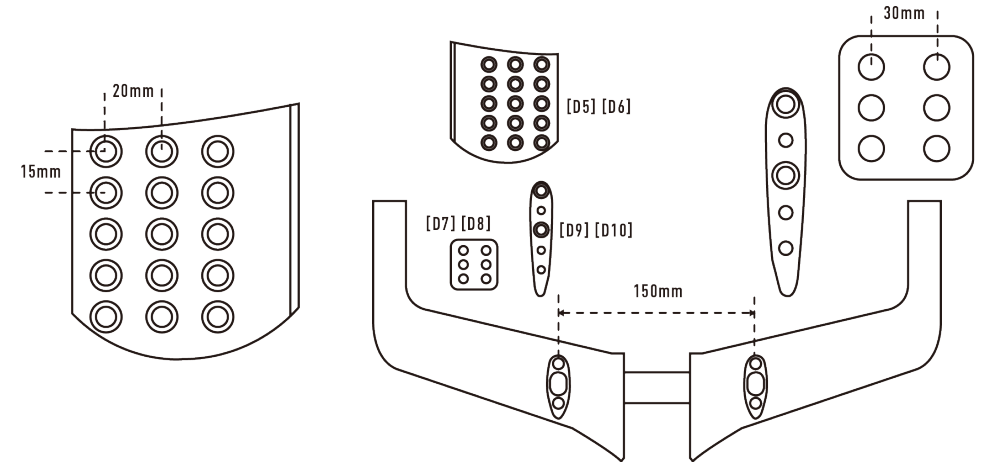

Step 6: Find the saddle position

There is 100mm of room for you to position the saddle at a seatpost angle of anywhere between 73 and 80 degrees. Please see the diagram on the right for your reference.

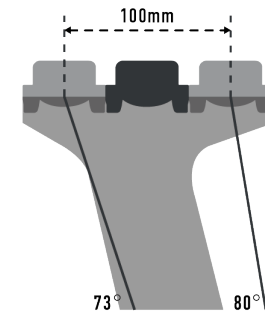

Front Brake Adjustment

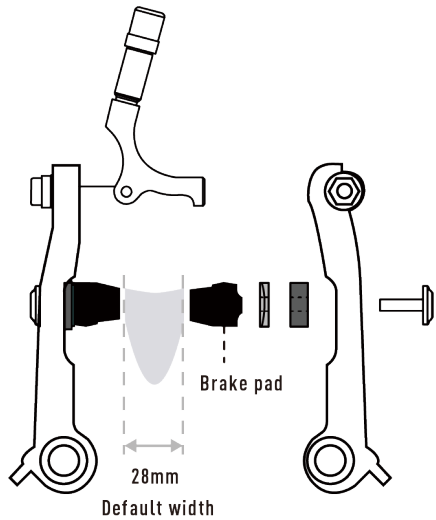

Wheel width	Semicircular washer	Washer	Bolt
more than 28mm	Install	None	14mm
24-25 mm	Install	2mm	15.7mm
19-20 mm	Install	4mm	17.7mm

i Front brake is already assembled on the fork. Default rim width is 28mm.

! To ensure brake efficiency and safety, please follow the chart below and use the correct washer and bolt with the corresponding wheel width.

Screw Torque Value Guide

[J1] SEAT POST CLAMP	5 Nm
[A3] ALLOY STEM CAP	2 Nm
[A1] STEM	Max. 6 Nm
[D1-D12] EXTENSION BAR RISERS & PLATE	Max. 6 Nm
[A5] STEM BLOT	5 Nm
[C1] COMPUTER MOUNT	5 Nm
[E1] ARM PAD	5 Nm
BOTTLE CAGE	4 Nm
SADDLE CLAMPING	4 Nm

i Fitting trial assembly and final assembly are both recommended to follow torque values when tightening the screws.

! Recommended torque value is applicable under most circumstances. Since such information is not specified by DARE, please refer to the sign on the bike or the gadget instruction manuals for details.

Unboxing & Assembly



The DARE EZBOX is a carton which is designed for transportation. Its purpose is to allow the user to transport their bicycle frequently whilst minimising storage space. The packing and storage instructions are detailed on the box itself. (The image is just for reference) Please refer to these instructions to pack the bicycle properly. An EZ-Box wheels can be purchased separately to allow the box to be transported more easily. See more details on www.dare-bikes.com/download.

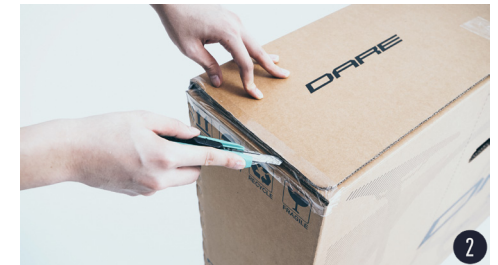

It is very easy to unpack the carton. Please follow the instructions step by step to avoid any mistake result in injury or damage. Begin by using a small knife such as a utility knife to cut the tape. Be sure to use a suitable knife to prevent damage to the bike.



Once opened you will see that 85% of the bicycle has been assembled (including the rear wheel and main components). The front wheel, seat-post and handlebars are packed separately, and there's also a tool box within the carton which includes spare hangers, screws, a front wheel quick release skewer, carbon friction paste, a 5NM torque wrench set, bicycle reflectors, some small parts, a DARE Manual and any additional-purchased products (the Di2 accessories will include a battery charger).

i When assembling the bike, it will be easier and quicker to do so with another person. Although it can be done by yourself with a bike rack or the EZBOX.

i Each model will have different components. Please refer to the specification on the website.

TAKE OUT THE MAIN BODY OF THE BIKE



Take out the tool box and the corrugated paper fixture below, open the toolbox and remove the tools.

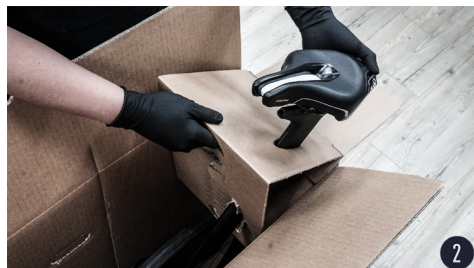

Remove another corrugated paper fixture on top of the rear wheel, then take the seatpost out (and put it to one side.)



Lift the top tube and carefully take out the main body of the bicycle.



Position the forks on the ezbox and balance the bicycle so as not to topple. If available, use a bike holder to secure the rear wheel. If not, you can use the corrugated paper fixture as a temporary alternative. (But please be aware that this is not as stable as bike holder.)



After you assembly your bike, please wrap the high-density foam with the Velcro strap. Place the user manual, 5Nm torque wrench set and other gadgets used to protect the bike inside the tool kit.

⚠ When lifting the bike, do not loosen the Velcro but keep the wheels and handlebar fixed on the bike to prevent anything falling and becoming damaged.

⚠ Do not use any equipment fixed on the main body (frameset) to stabilize the bike. Use an alternative method to fix the seatpost and frameset. For example, corrugated paper seat or ideally another person.

ASSEMBLE THE RISER KIT

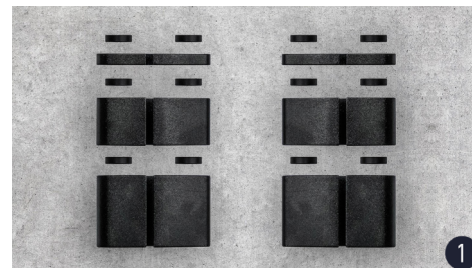

Take out risers and washers. Please look up **CHART D** on p.14 for bolts and screws' lengths.



Insert the bolts F1 through the C3 its dented side facing downwards) and handlebar. Note: The C3 is irregular. Ensure that the big side faces forward and small side faces backwards.



Place 1.5mm washers [G1].



Place suitable risers base on your fitting data. Please do not forget to insert 3mm washers [G2] between risers.

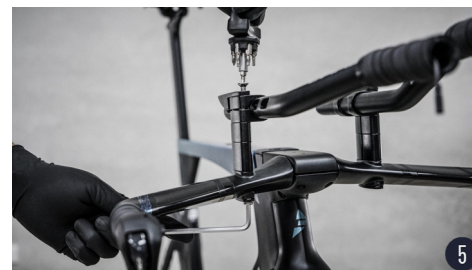

When reaching the sufficient height, place 1.5 mm spacers [G1], then place the extension bar clamps [D9, D10] and the arm pad mounts [D7, D8]. Use the No. 5 hex wrench on top and the No. 4 torque wrench on the bottom to tighten the screws and bolts.



Install the arm pads [D5, D6].



Adjust extension bars and tighten the mount bridge [C1].



Paste the arm pads onto the arm pad plates.



Make sure it is stable and fits your personal setting.

ASSEMBLE THE ARM PADS AND EXTENDED PLATES

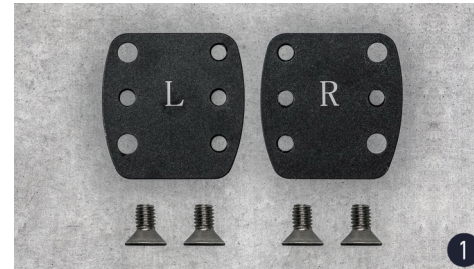

Take out the extended plates [D5, D6] and screws from the tool box.



Loosen bolts and screws then remove the arm pad mounts [D7, D8]. Add the extended plates [D5, D6] (Letters facing downwards, R on the right hand side and L on the left hand side). Tighten the bolts and screws again.



Use the No. 5 hex wrench and the No. 4 torque wrench to tighten the screws by 5Nm.



Screw the arm pad plates on the corresponding spot on both sides by 5Nm.



Paste the arm pads onto the arm pad plates.

ASSEMBLE THE SEAT POST



1

Take out the seat post clamp [J1] from the accessory box. Please keep the gap of the seat post clamp larger than 1.5mm; otherwise, the seat post might not be properly fastened.



2

Apply little carbon friction grease onto the bottom of the seat post.



3

Firmly press the seat post clamp and insert the seat post.



4

Adjust the seat post height base on your fitting data.



5

Tighten the seat post clamp by 5Nm.

FRONT WHEEL INSTALLATION AND DOUBLE-CHECK



1

Loosen the screws.



2

Pull open the brake cover.



3

Remove front brake quick release on one side.



4

Remove front brake quick release on the other side.



5

Put the front wheel into the fork, and slightly adjust the quick release axis so the fork leg can fit into it.

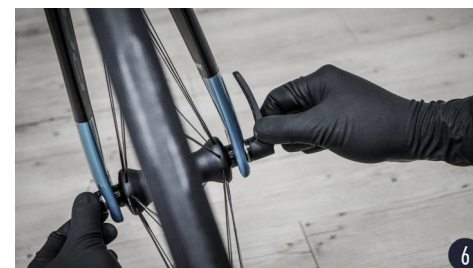

6

Tighten the quick release.



Check and adjust front brake according to Front Brake Adjustment on p. 16.



Attach front brake cover.



Please pull out the excess brake line out of the front brake cover to make sure the braking efficiency.

Recommended Torque Value

DARE products		
Frame	Water bottle bolts	4-5 Nm
	Cable holder screw	1.5 Nm
	BB lower cablegude	3 Nm
	Chain catcher screw	1.5 Nm
	Front derailleur mount	3 Nm
	Rear derailleur hanger screw	1.5 Nm
	TSR front derailleur cable tube	3 Nm
Seat post clamp	Seat post clamp screw	5 Nm
Seat post	MR1s saddle clamp	15 Nm
	VSR/TSR saddle clamp	12 Nm
Stem	Front cap screw	5 Nm
	Lateral front fork screw	5 Nm
TSR Stem	Carbon fiber stem top cap	1.5 Nm
	Front cap screw	5 Nm
	Lateral front fork screw	5 Nm
	fork steel screw	5 Nm
TSR handlebar	Arm pad screw	5 Nm
	Aero bar screw	5 Nm
	Computer mount	3 Nm

Assembly parts		
Rear derailleur	Rear derailleur hanger mount screw	10 Nm
	Jockey wheel	3 Nm
	Shift cable stop	5-7 Nm
Front derailleur	Front derailleur hanger mount	5-7 Nm
	Shifting cable screw	5-7 Nm
Lever	Hex socket set screw	5 Nm
Cassette	Cassette cover	30-50 Nm
Crankset	Crank screw	12-14 Nm
	Plastic cover	0.7-1.5 Nm
Pedal	Pedal axle	35-55 Nm
Brake	Mount frame screw	8-10 Nm
	Brake shoe set screw	5-7 Nm
	Brake shoe screw	2 Nm

⚠ Suggested torque value is applicable under most circumstances. Since such information is not specified by DARE, please refer to the sign on the bike or the gadget instruction manuals for details.

Carbon Fiber Bike Statement

1. Carbon fiber silk is a type of polymer fiber made from artificial chemical fiber with higher than average carbon content and manufactured via series of rigorous and complex processes such as drawing, oxidation, carbonization and graphitization inside a furnace.
2. The carbon fiber used to manufacture a DARE bike is composed of a carbon fiber silk with high polymer resin which gives it a sticky quality that enables layers to be stuck to one another. After the hot molding process, its tensile strength can be up to 7~9 times stronger than an equivalent made of steel but its compressive elastic modulus is also higher than steel. Moreover, the strength of aerospace high-rigidity high-modulus carbon fiber is yet higher with their weight being only one quarter of a steel equivalent.
3. Carbon fiber is a low-density material and hence light, so it is ideal for use in the production of bike frames and associated products. Also, the rigidity and strength of these products can be enhanced at a material level by using different permutations and stacked angles of carbon fibers. DARE uses computer processing to aid in the designing and analysis of permutation, layout, and strength of carbon fiber material. Combined with the experience gained through years of manufacture and rigorous testing, DARE has developed both a light and sturdy high-quality product.
4. The assembly and maintenance of carbon fiber frames is completely different from those of steel bikes or aluminum ones. DARE strongly advises that you only use DARE-authorized bike service professionals.
5. The physical properties of carbon fiber and metals are different. Under normal usage and without inappropriate internal stress or external impact, the material fatigue of carbon fiber bikes is much lower than those of aluminum and steel bikes. However, when a carbon fiber bike suffers excessive internal stress, external impact, or poor packaging when in transit, it is more likely to crack than bend. Such cracks may be invisible to the naked eye initially but are likely to expand through continued bike use, which will of course endanger the bike rider's safety. To prevent any such accidents, please return the bike to the original dealer for a professional inspection, according to the maintenance schedule and plan in the instruction warranty manual.
6. All lightweight carbon fiber frame tubing is very thin. Inappropriate paint spraying may cause surface damage during the removal of the original paint. As such, re-spraying is strongly discouraged. Such re-spraying of any part of the bike will invalidate the warranty and DARE will bear no responsibility for any associated damaged.

Warranty Terms & Conditions

WARRANTY LIFETIME

The warranty is limited to the defective goods direct from the manufacturer and is only valid for the initial owner of the bike. As such, the warranty is not transferred upon sale of the bike.

1. The original warranty period is three years from the date of receipt (36 months) The warranty period will be extended to 6 years (72 months) if the customer completes the online registration within 30 days of the date of delivery.
2. If any product manufactured by DARE is deemed defective and falls within the remit of the terms and conditions, it may be repaired or exchanged. If such a product has been discontinued, it will be replaced by a similar value product.
*If a non-DARE product is deemed defective please contact to product's suppliers directly.
3. Please store your warranty card, receipt and the proof of purchase in a safe place.
4. DARE maintains the right to make the final decision regarding fixing, changing or replacing a defective item.
5. Additional services such as bike maintenance and shipping are not included in the warranty.

WARRANTY CLAIMS

1. When progressing a warranty claim the following information is required: proof of purchasing, serial No., photos of the bike and the damage part. Email this information to the DARE SERVICE MAIL-BOX: service@dare-bikes.com. We will reply to you as soon as possible.
2. The warranty lifespan will stay the same regardless of any changes made to the product.
3. If a product is replaced under warranty the defective (original) will belong to DARE.

CRASH AND REPLACEMENT PLAN

Register your bike via www.dare-bikes.com within 30 days of the date of your purchasing to become part of our "Crash and Replacement Plan". This plan is valid to the original purchaser for 3 years from the date of purchase as shown on your receipt. Please ensure that all details submitted are correct. In the event of an accident or crash such damage may occur to the frame/fork which would make the bicycle unfit to ride. Any such damaged incurred which is excluded from the warranty terms and conditions can be covered by our Crash and Replacement Plan. For a special price* we will offer to exchange the same or similar product (only DARE frames, forks, handlebars, and seatposts are covered by the plan and non-DARE products such as wheels, derailleurs and saddles etc. are excluded). *Check out the official DARE website: www.dare-bikes.com.

Please contact us by email and include details of the damage to your bicycle with photographic evidence. DARE will then inform you how to proceed with the Crash and Replacement Plan after evaluating your information.

- If DARE has reason to believe that the damage reported was caused deliberately the right of replacement could be forfeited depending upon the judgement of DARE.
- The replaced defective product will be returned to DARE who will also become the owner.

FREE RETURN WITHIN 7 DAYS

If you find any damage to your purchases after unpacking your shipment, please retain the original packaging and do not attempt to assemble or ride the bicycle. Contact DARE customer services. Upon confirmation from DARE that free return of the bike must be made within 7 days, you will have the right to an exchange or refund. After 7 days, the right to an exchange or refund is forfeited and DARE will have the right to decide the course of any future action.

MODIFICATION PERMISSIONS

DARE maintains the right of cancellation or revision of the Crash and Replacement Plan at any time without personal notification. Any such notifications can be found on the official website at www.dare-bikes.com.

THE FOLLOWING ITEMS ARE EXCLUDED FROM THE CRASH AND REPLACEMENT PLAN:

1. Consumable components including but not limited to: tires, brake pads, brake cables, gear cables, handlebar grips, sprockets, chains, freewheels, wheel rims, hubs, and so on.
2. Those without a proof of purchase date or receipt.
3. Those DARE items which are not covered by the warranty period.
4. Those with an indecipherable or incorrect model and/or serial number.
5. Those with a serial number that has been removed or altered.
6. Those which have been operated or maintained incorrectly as determined by the relevant instruction manual.
7. Those which have been subject to improper cleaning agents or incompatible accessories.
8. Those which have been modified or changed compared to the original specification, painting or parts.
9. Those which generate noise during rotation but which does not influence its function.
10. Those used for renting or frequently lending to other riders.
11. Those which naturally fade and those which suffer from the peeling of metal surfaces or plastic

parts, due to improper storage.

12. Those with appearance defects after the 7-day appearance warranty has expired (free return within 7 days).
13. Those with damage or failure caused by the following:
 - Man-made damage, negligence, abuse and abnormal uses.
 - Improper assembly (eg. Improperly using the wrench), maintenance or repair by a non-authorized DARE store.
 - Disassembling components recklessly or carelessly and/or using non-original or modified parts.
 - Surface colour fading or corrosion of metal surfaces due to the passage of time or UV radiation.
 - Repainted (in part or full) products.
 - Natural disasters, such as earthquakes, typhoon, floods, fires, and so on.
 - Accidental collisions (Improper carriage, traffic accidents, impacts, shipping damage, or incorrect usage, etc.)
 - Overloading
 - Exhaust, chemicals, guanos, salt corrosion, and so on.
 - Consumable components not being maintained and/or replaced on time.
 - Use of the bicycle in any unsuitable environment or during competition and/ or commercial activities that include aggressive/reckless handling.
 - Exceeding the minimum insertion of the seatpost, resulting in deformation and damage to the frame.
14. DARE will charge for any component and associated labor during the repair process if the problem is deemed unrelated to any quality issue.
15. DARE will charge a fee for non-DARE products that require repair or replacement. A quote for such work will be provided beforehand.